



INDUSTRIAL/COMMERCIAL EVAPORATIVE COOLER

MODELS MS/MD 524 SINGLE INLET • MS/MD 628 DUAL INLET
DM080 (8" MEDIA) • DM120 (12" MEDIA) • UM080 • UM120

USE AND CARE MANUAL

Read This First!

NOTE!

Read And Save
This Manual –
“Important Safety
Instructions”

Note To Installer:
Please Deliver This
Guide To the Owner.

Caution: Read All
Instructions Carefully
Before Installation.

CAUTION

Read all instructions carefully before beginning the installation. Careful pre-planning will help avoid costly mistakes during the installation. These instructions contain important information needed to properly install and set up this cooler. Failure to follow these instructions may damage and/or impair the cooler's operation and void the warranty.

NOTE:

See instructions packed in Motor
Kits and Pump Kits for correct
installation of Motor and Pump.

INSTALLATION & START-UP

Read carefully before installing your Industrial Symphony evaporative cooler.

NOTE: Your warranty does not cover shipping damage. Report all shipping damage at once to dealer or carrier making delivery.

During routine inspection or service, this cooler can be accidentally started. Keep all personnel away from the cooler and electrical supply when it is being worked on. Don't attempt to perform any part of the installation described in this book unless you are fully-qualified to do so. All electrical work must meet local codes and national codes (N.E.C.) and must be performed by qualified personnel only.

SAFETY

CAUTION: Disconnect all electrical power to the cooler before attempting to install, open, or service your cooler.

If the cooler is thermostatically controlled, the thermostat is not to be used as a disconnect as it may reset and start the unit unexpectedly.

CAUTION: Do not allow pump to topple over and become submerged; water will damage pump motor.

CAUTION: All electrical installations must comply with local building and safety codes and must be performed by qualified personnel only.

CAUTION: Do not exceed maximum amperage output as stamped on the motor specification plate or motor can overload. Only qualified persons with proper electrical equipment and knowledge should adjust variable pitch sheaves. Do not allow water to get on the motor, as it will burn out the windings.

CAUTION: Disconnect all electrical power to the cooler and insure that belt is not rotating before adjusting belt tension. Do not adjust belt tension by changing diameter of adjustable sheave. Adjust belt tension only by adjusting motor bracket.

Before attempting to install the cooler, make sure the following preparations have been made:

- Assure that the mounting surface is strong enough to bear the weight of the cooler when in use, remember that when the system fills with water, the cooler will be much heavier than when dry. (For operating weight, see accompanying parts list.)
- Make sure you have adequate means for lifting the cooler in place.
- Check the electrical supply to see that it matches the requirements shown on the motor name plate.
- Make sure the mounting surface is level in all directions.
- Make sure any duct work and electrical needs comply with local and national codes.

LOCATION

Down discharge commercial and industrial coolers are designed for installation on either flat or pitched roof (Figure 1). Side discharge coolers

are designed for installation on side of a building (Figure 2), or they may be installed on roof by using a transition duct from cooler opening to building duct (Figure 4).

Commercial and industrial coolers are usually connected to a duct system or ceiling diffuser for air distribution throughout area to be cooled.

Install cooler so only fresh outside air enters cooling system. Avoid installing unit in closed-in areas, such as an attic or storeroom, which restricts free air movement around cooler. Avoid installation near vent pipes, kitchen exhaust, etc., as odors or fumes may be drawn into unit.

When coolers are installed on roof to cool large rooms such as factories, auditoriums or supermarkets, divide cubic area of room and strategically locate units of proper capacity to cool divided areas. Install straight duct from roof to ceiling and use ceiling diffusers to distribute air throughout area (Figure 1 and Figure 3).

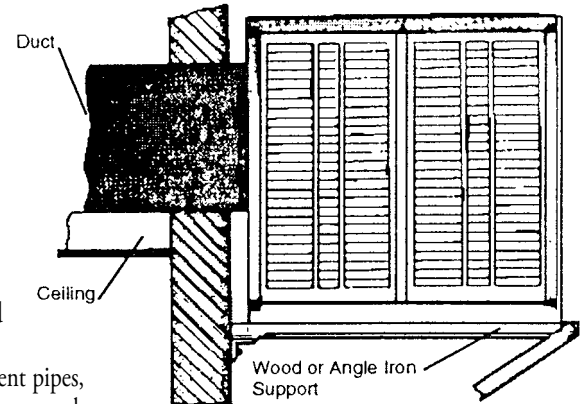
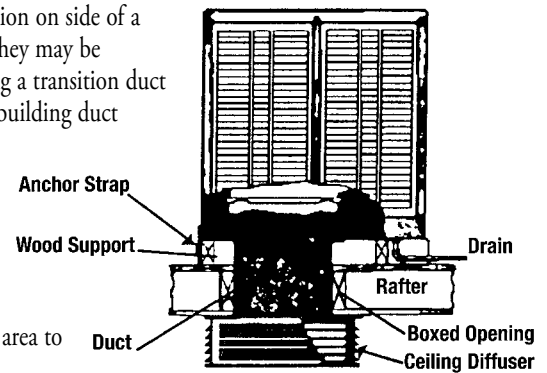

FIGURE 2

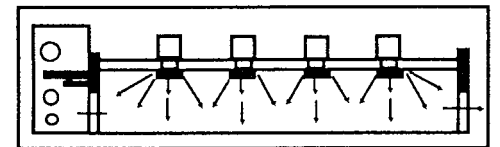

FIGURE 3

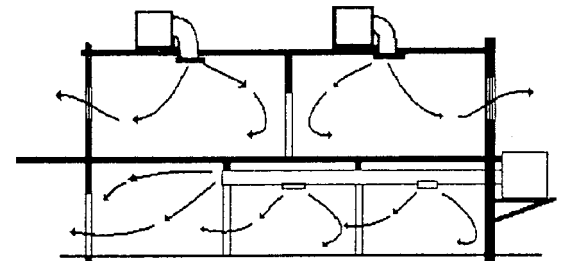

FIGURE 4

DUCT SYSTEM

Air can be delivered over a distance to individual rooms or areas by means of a duct system. The duct system, which is tailored to fit the building, should be fabricated and installed by a competent sheet metal contractor, preferably while building is under construction. A typical duct system consists of a main duct with same dimensions, or larger, than blower opening of cooler, and duct branches which are sized according to cubic area of rooms to be cooled.

Correct cooler size is determined by dividing desired number of minutes air change into total cubic meters of building. Example: A building with an inside area of 30,000 cubic feet, using air change every two minutes, would require one 15,000 CFM cooler or two 7,500 CFM coolers. The size of duct opening in each room is determined by multiplying the square inches of

cooler blower opening by two and dividing area proportionately to room size.

Reduction on side of duct immediately after a branch acts as an air scoop for branch take-off. On ducts using square corners, turning vanes are desirable for free air flow around corners and duct branches. To control volume and direction of air in individual rooms, registers with adjustable or fixed louvers are attached to ends of duct branches.

AIR EXHAUSTING

Windows or doors at a point most distant from cooled air inlet should be left open to permit free movement of air out of area being cooled and avoid building up static pressure. Proper location of exhaust openings is important as they guide flow of air through areas where cooling is desired. Using standard CFM ratings, a common method for determining how much to open doors or windows for proper exchange is: 2 square feet per 1,000 CFM.

COOLER INSTALLATION

UNIT ASSEMBLY

The blower-module and media modules are shipped separately. Upon installation bolt modules together using brackets provided. Be sure to install star washers as shown (Figure 5), to provide ground continuity between the units. Caulk between the units to maximize cooling. A gasket is included in the parts bag to be used along the removable top panel of the media section.

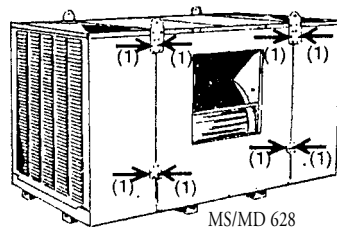
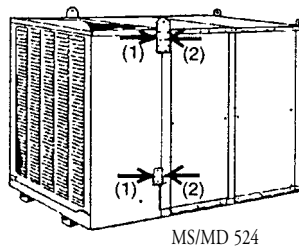

FIGURE 5

Arrows indicate position of star washers on brackets, quantity required in ().



MS/MD 524

HOISTING

For ease of hoisting, lifting brackets have been provided. Assure that hoisting equipment is of adequate capacity and that all four lift brackets are used when lifting. Use a spreader bar to lift unit as shown (Figure 6) (MD628 shown).

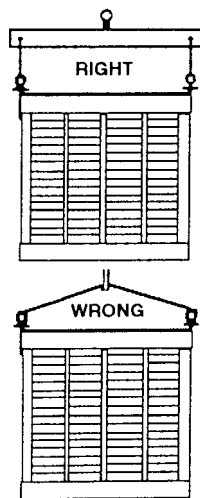
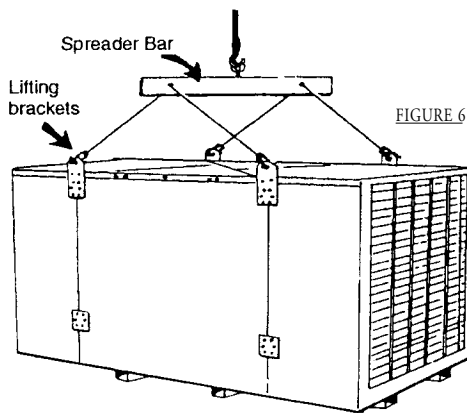

CAUTION Be careful not to lift in such a way that could cause lifting brackets to bend.

ELECTRICAL INSTALLATION

ELECTRIC POWER

Be sure cooler is connected to proper line current, voltage and cycle as stamped on cooler motor and pump motor specification plate. Check with local power company if in doubt.

Note: Improper voltage will void motor guarantee.

CAUTION: All electrical installations must comply with local building and safety codes and must be performed by qualified personnel only.

The horsepower, voltage, cycle, phase, current, number of speeds of motor and length of wire required from switch to motor will determine the gauge of wire to be used.

Larger horsepower and three-phase applications require switches and/or starters of proper current capacity and should be installed by a competent electrician.

ELECTRICAL GROUND

For maximum safety precaution, make sure cooler cabinet is properly grounded to a suitable ground connection.

CAUTION: Disconnect all electrical power to the cooler before attempting to install, open, or service your cooler. If the cooler is thermostatically controlled, the thermostat is not to be used as a disconnect as it may reset and start the unit unexpectedly.

MOTOR INSTALLATION

- Install motor using four carriage bolts provided. Use Figure 13 located on page 10) to determine proper hole pattern for models MS 628 and MD 628.
- Check motor mounting to be sure all screws and nuts are tightened.
- Wire motor for proper rotation. See arrow on blower housing.
- Insert sheave onto the motor shaft.
- Rotate blower wheel by hand to see that it moves freely without rubbing against housing.
- Install belt from motor sheave to blower pulley.
- Align belt by vertically centering motor pulley in-line with blower pulley (Figure 7).

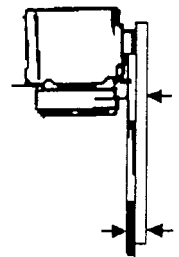

FIGURE 7

ADJUSTABLE MOTOR PULLEY

When cooler is connected to extended ductwork, the cooler capacity and motor amperage may decrease due to duct resistance. The adjustable motor pulley (sheave) is used only to return cooler and motor to maximum load capacity and should not be readjusted except for this purpose.

Correct belt tension and alignment is important as it

CAUTION: Do not exceed maximum amperage output as stamped on the motor specification plate or motor can overload. Check amperage with all windows and doors open and all relief systems operating. Improper pulley adjustment will overload and burn out motor. Only qualified persons with proper electrical equipment and knowledge should adjust variable-pitch sheaves.

CAUTION: Never operate unit with service panels, media or inlet panels removed. This will result in an overloaded condition and may damage the blower motor.

CAUTION: Disconnect all electrical power to the cooler and insure that belt is not rotating before adjusting belt tension. Do not adjust belt tension by changing diameter of adjustable sheave. Adjust belt tension only by adjusting motor bracket.

cuts power consumption and prolongs life of belt and motor. When installing or adjusting belt, loosen the motor adjustment bolts and adjust for proper tension for each model as listed below. Do not tighten belt by adjusting motor pulley. Align belt vertically by centering motor pulley in-line with blower pulley (Figure 7).

MS524/MD524 • MS628/MD628	
MOTOR HP	BELT TENSION
3/4	25 lbs.
1	25 lbs.
1-1/2	25 lbs.
2	25 lbs.
3	35 lbs.
5	35 lbs.
7-1/2	40 lbs.

INSTALL OVERFLOW STANDPIPE AND DRAIN LINE

Install overflow drain busing in bottom of cooler. Slide rubber washer over drain bushing, push drain bushing through bottom of cooler and tighten nut. Screw plastic overflow standpipe into the drain bushing and tighten snugly to prevent leakage. Connect a drain (copper/pvc/garden hose) to drain bushing and drain in accordance to local codes (Figure 8).

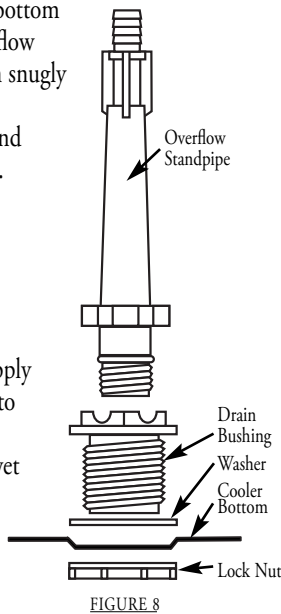

CONNECT WATER SUPPLY

Connect water line to cooler (Figure 9):

- A water valve should be installed at a convenient location to allow the water supply to be turned on and off. Use 1/4" tubing to provide water to the cooler.
- Install float valve in the side panel of the wet section near the blower service panel.
- Place tube nut and ferrule over end of tubing.
- Insert tube into float valve and tighten.

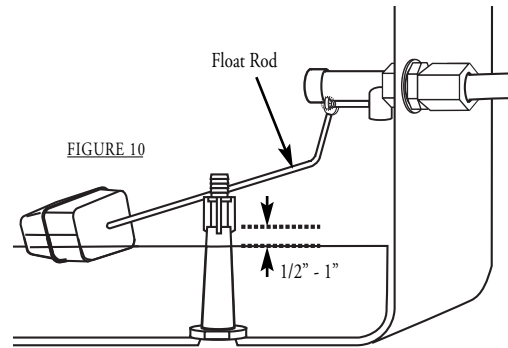
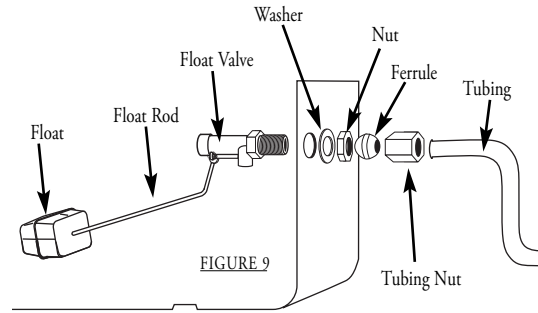

ADJUSTING WATER LEVEL AND FLOAT VALVE

Fill reservoir as follows:

- Turn water supply on. Check for good pressure and flow from float valve.
- When float valve shuts off, check water level. Water level should be 1/2" to 1" below the opening of overflow standpipe.
- Adjust float valve if necessary by bending the float rod (Figure 10).

RECIRCULATING PUMP

Recirculating pumps are necessary for operation. Use one pump for each media module.

MOUNTING PUMP

Mount pump in bottom pan as close as possible to entrance in blower section. Use bracket, screws, star washer and nuts provided in parts bag in the wet section (Figure 11).

INSTALL BLEED-OFF

A bleed-off system can be purchased with your cooler. Its purpose is to eliminate a small quantity of water from recirculation thus helping reduce scale build-up. The bleed-off assembly requires inserting the bleed-off hose into the pump assembly and

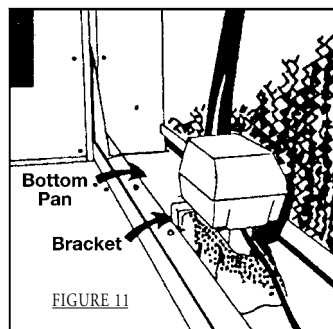

CAUTION: Do not allow pump to topple over and become submerged; water will damage pump motor.

CAUTION: All plumbing installations must comply with local building and safety codes and must be performed by qualified personnel only.

routing the bleed-line through standpipe opening.

1. Install one end of bleed-line into pump assembly bleed-off tap.
2. Insert other end of bleed-line into standpipe.
3. Install clamp with screw on bleed-line.
4. Adjust screw to obtain flow rate for appropriate model indicated below.
5. Water must be drained in accordance with local codes.

MODEL	MOTOR HP	BLEED RATE (GPH)	TIME TO FILL 12 OUNCE CONTAINER (BEVERAGE CAN) IN SECONDS
MS524	3/4	30	42
MD524	1	34	38
	1-1/2	37	34
	2	45	28
	3	53	24
MS628	1	42	31
MD628	1-1/2	49	26
	2	57	23
	3	68	19
	5	83	15
	7-1/2	95	13

! **NOTE:** Bleed rate may degrade slightly after two weeks and should be checked two to four weeks after initial setting and readjusted.

PERIODIC INSPECTION

In addition to the planned maintenance schedule, regular inspection of your Symphony Premium Industrial cooler will enhance the performance and its service life.

CHECKLIST

- £ Check for leaks.
- £ Check for dry spots on the media when cooler is in operation.
- £ Snug down all bolts, nuts and set screws.
- £ Make sure cooler remains level.
- £ Check that blower turns freely.
- £ Check float is set correctly.
- £ Clean water pan.
- £ Check for proper belt tension.

ADJUST BELT TENSION

Each time you inspect your cooler, be sure to check belt tension on motor/blower assembly. Check belt condition and replace if frays or defects appear. Check alignment of blower pulley with motor pulley (see page 4 for detailed steps).

! **CAUTION:** Disconnect all electrical power to the cooler and insure that belt is not rotating before adjusting belt tension. Do not adjust belt tension by changing diameter of adjustable sheave. Adjust belt tension only by adjusting motor bracket.

! **CAUTION:** Disconnect all electrical power to the cooler before attempting to install, open, or service your cooler. If the cooler is thermostatically controlled, the thermostat is not to be used as a disconnect as it may reset and start the unit unexpectedly.

! **CAUTION:** Do not allow pump to topple over and become submerged; water will damage pump motor.

CLEANING WATER PUMP

Disassemble and clean water pump as follows (Figure 12):

- With power supply disconnected, unplug pump cord. Remove pump.
- To prevent breakage, carefully release the four snap-out tabs and lift impeller base plate from the pump body.
- Using a mild detergent solution, wash all deposits from inside around impeller and impeller base plate.
- Spin impeller to dislodge any foreign material.
- Rinse and reinstall impeller base plate.
- Reinstall pump.
- Connect cord.

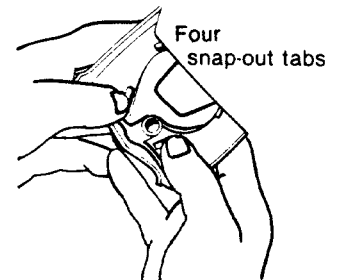

TIGHTENING SET SCREWS AND NUTS

Set screws and hardware that should be tightened:

- Split taper bushing bolts: 150 in-lbs
- 2 blower set screws: 150 in-lbs
- Wet and dry module connection bolts: snug

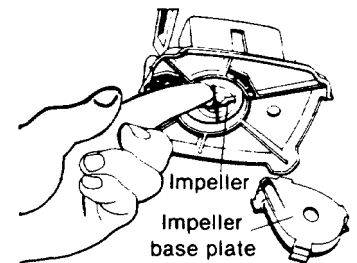

FIGURE 12

LUBRICATION

The motor bearings are oiled at the factory, but should be checked before operating cooler. If need for oiling is indicated, use any good grade S.A.E. 20 or 30 wt. oil. Apply 2 or 3 drops of oil into each oil cup on cooler motor. Under normal use, oiling is required about every 3 months of operation. **DO NOT OVER OIL.** The blower shaft bearings are permanently lubricated and need no oiling.

CHANGING AND WASHING MEDIA

Media should be replaced after 5 years or if passages are clogged. Note: hosing off inlet face of media can unclog passages of dust and minerals that



CAUTION: Avoid splashing water on blower motor.

have accumulated. Light scraping of the intake edges of the media will not harm its openings and will remove stubborn scale.

MEDIA REPLACEMENT

- Remove media section top.
- Remove water distributor assembly and disconnect hose.
- Lift out used media sections.
- Replace with new Symphony media available from your dealer. Aspen and other evaporative media WILL NOT WORK.
- Be sure that the media sections are in correctly. the dark stripe or dot painted on the media should be to the outside at the bottom.
- Replace water distributor assembly and reconnect hose.
- Replace media section top.



CAUTION: Disconnect all electrical power to the cooler before attempting to install, open, or service your cooler. If the cooler is thermostatically controlled, the thermostat is not to be used as a disconnect as it may reset and start the unit unexpectedly.



CAUTION: Never wash your cooler cabinet with a garden hose; water may harm blower motor and pump motor and/or seep into ductwork.

DRAINING

Clean the cooler cabinet (with power off and panels removed) as follows:

- Connect a drain hose to the drain fitting on the bottom of the reservoir.
- Remove standpipe from the drain fitting.
- Drain and clean reservoir. Never drain water onto a roof.

TOUCH-UP

The hardness, adhesion and smoothness of the finish on your cooler makes it extremely unlikely that scratches or chipping will occur. In the event that finish damage does occur, it should be promptly repaired using the following procedures:

Painted Parts

The area around bare metal spots, either internal or external, should be sanded or rubbed with steel wool to prepare the finish to accept paint. Prime and paint with standard paint or with matching touch-up paint available through your dealer. Do not use asphalt-type cooler undercoat material in water reservoir.

GETTING THE MOST FROM YOUR COOLER

Your evaporative cooler is a finely crafted economically operating unit built on decades research and development and serves as the heart of an overall air-cooling and moving system. There are a number of ways you can further maximize the comfort, efficiency, economy and convenience of your cooling system.

BLEED-OFF

Bleed-off components are available for each cooler and should be installed in accordance with the "Installation instructions for Bleed-off Assembly".

MAINTENANCE

Regular maintenance as recommended in this manual is essential for cooling comfort, extending the life of your cooler and avoiding unnecessary part replacements. Start-up, mid-season and shutdown servicing should never be overlooked. Clean pads at least twice per season or more if mineral deposits or dust build up.

REPLACEMENT PARTS

When ordering replacement parts always refer to the serial and model number of your cooler. Use the part numbers listed in the accompanying parts list, as illustrated in the diagrams for your model.

GENERAL WIRING INSTRUCTIONS

All installations should be done in accordance with National Electric Code, (N.E.C.) Article 110.

Safety Disconnect Switch(es) - Shall have minimum enclosure classification compatible with the installation location and installed in accordance with N.E.C., Article 430. The disconnect switch shall be a U.L. Listed disconnect which breaks all ungrounded conductors that can carry current to the unit.

Over-current (short circuit) Protection - Devices intended to protect the motor branch-circuit conductors, motor control apparatus and motors against overcurrent due to short circuits or ground faults shall have minimum enclosure classifications compatible with the installation location and installed in accordance with N.E.C., Articles 240 and 430. These devices shall be U.L. Listed short circuit protection devices and sized in accordance with specifications as stated in N.E.C., Article 430.

Overload Protection - All single phase motors available from Impco, for use in industrial/commercial units have integral thermal overload protection (running and locked rotor). All 3-phase motors require overload protection sized and installed in accordance with N.E.C., Article 430. (See motor starter.)

Motor Start Switch - In applications where a switch is adequate to start the motor, as defined by N.E.C., Article 430, the branch circuit shall be sized in accordance with N.E.C., Article 210 and 430. The enclosure for the switch and its location shall comply with N.E.C. requirements for the installation of the switch.

Motor Starter - Device with integral thermal overload protection used to start/stop 3-phase motors. Motor starter shall be sized in accordance with specifications as stated in the N.E.C., Article 430. A general recommendation for sizing the starter is tabulated on a label attached to the blower housing of each unit. Starters mounted to unit shall have minimum NEMA 3R (raintight-rainproof) enclosure rating. Starters mounted remote to the unit shall have minimum enclosure classification compatible with the installation location and installed in accordance with N.E.C., Article 430.

Control Circuit Transformer - Shall be N.E.C. class 2 transformer of adequate capacity and installed in accordance to national and local codes.

Pump Transformer - When required, transformer shall have a minimum ampacity of 250 VA and have, or be located within, a minimum enclosure classification compatible with N.E.C., Article 450.

Pump Circuit - The pump circuit, if not operating on a transformer, shall have overcurrent protection of 15 AMP or smaller and have a minimum of #14 AWG copper wire to the pump receptacle. The pump receptacle shall be a Ground Fault Circuit Interrupter (G.F.C.I.) type receptacle or protected by a G.F.C.I. circuit breaker and shall be mounted in an outside type (NEMA 3R), raintight-rainproof) box and cover. The recommended location for the receptacle box to be attached to the unit is shown on page 9 of the Owner's Guide. Conduit to the receptacle box shall be raintight or liquidtight, flexible metal, flexible metal conduit with a separate ground wire, installed in accordance with N.E.C., Article 351.

WIRING DIAGRAM - POWER SUPPLY CROSS REFERENCE		
POWER SUPPLY	CONTROL CIRCUIT	SEE WIRING DIAGRAM
120 Volt 1 phase	120 Volt in-line switch	A
120 Volt 1 phase	24 Volt relays & control thermostat	C
208 or 240 Volt 1 phase	240 Volt in-line switch	B
208 or 240 Volt 1 phase	240 Volt relays & control thermostat	D
208, 240 or 480 Volt 3 Phase	120 Volt relays & in-line switch	E
208, 240 or 480 Volt 3 Phase	240 Volt relays & in-line switch	F
208, 240 or 480 Volt 3 Phase	24 Volt relays & control thermostat	G

SYMBOL LEGEND

See general wiring instructions for description/requirements of components.

- SD1 Safety disconnect, motor/pump circuit.
- SD2 Safety disconnect, pump/motor circuit on separate power supply.
- FB1 Over current (short circuit) protection device, fuse or inverse-time circuit breaker sized for motor circuit (per N.E.C.).
- FB2 Overcurrent (short circuit protection device, fuse or inverse-time circuit breaker (G.F.C.I. Type) sized 15 AMP or less for pump/control circuit (per N.E.C.).
- SW1 Motor start/stop (on/off) switch.
- SW2 Pump switch (cool/vent).
- SW3 Motor speed switch (low/high).
- R124V control relay, motor on/off.
- R224 v control relay, pump, cool/vent.
- R324V control relay, motor speed, low/high (NO/NC).
- MS Motor starter, control relay w/thermal overload.
- MP Media pump EP280A (120) or EP480 (240).
- XFMR1 ... Control transformer, 120, 208/240 or 480V primary/24V class 2 secondary.
- XFMR2 ... Pump transformer, 208/240 or 480V primary/120V secondary, 250VA minimum
- BLWR MTR .Blower motor: Single phase - 1 or 2 speed, thermally-

protected. Three phase-not thermally-protected, use appropriately-sized motor starter w/ thermal overload protection per N.E.C. requirements.

PR Pump receptacle, ground fault circuit interrupter (G.F.C.I.) type receptacle or protected by a G.F.C.I. type circuit breaker. Mounted in a weatherproof box with cover.

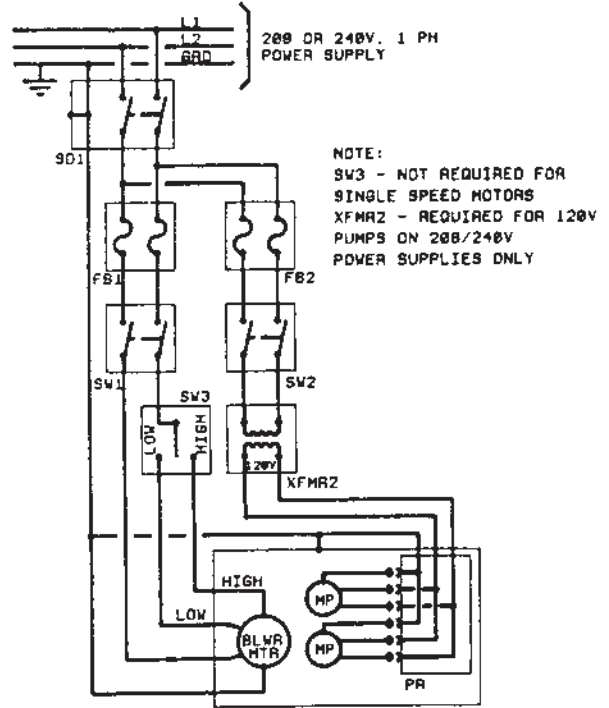

WIRING DIAGRAM B

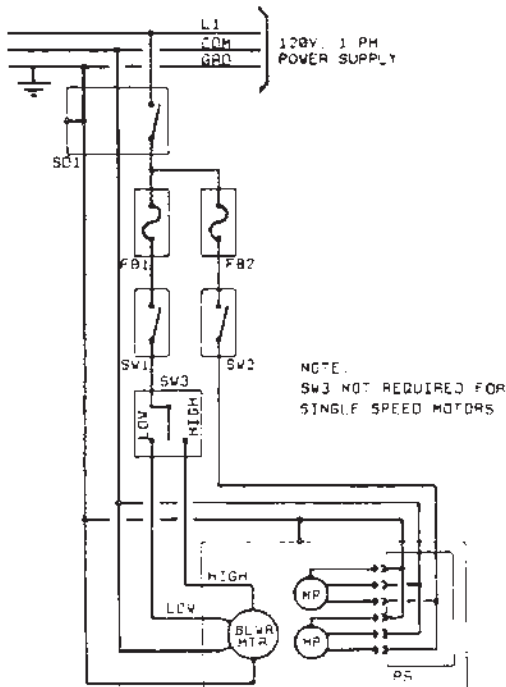

WIRING DIAGRAM A

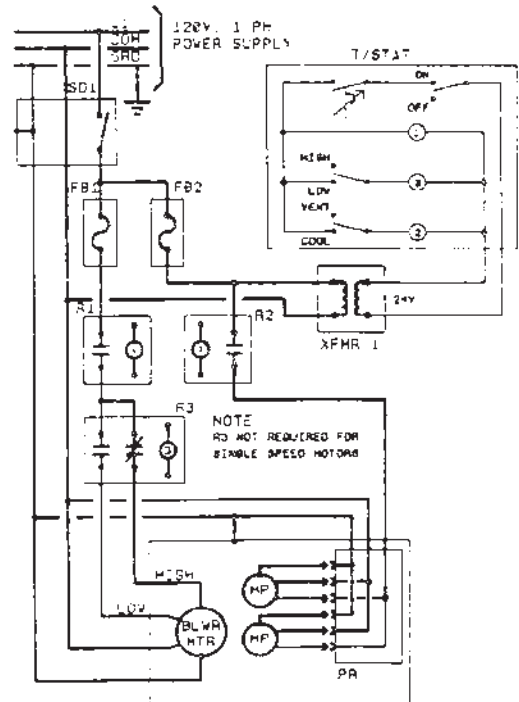

WIRING DIAGRAM C

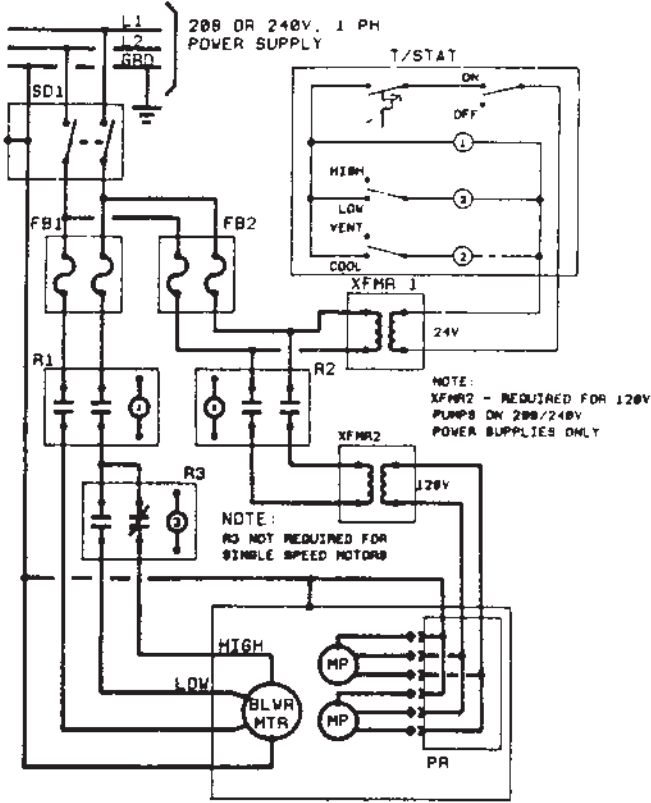

WIRING DIAGRAM D

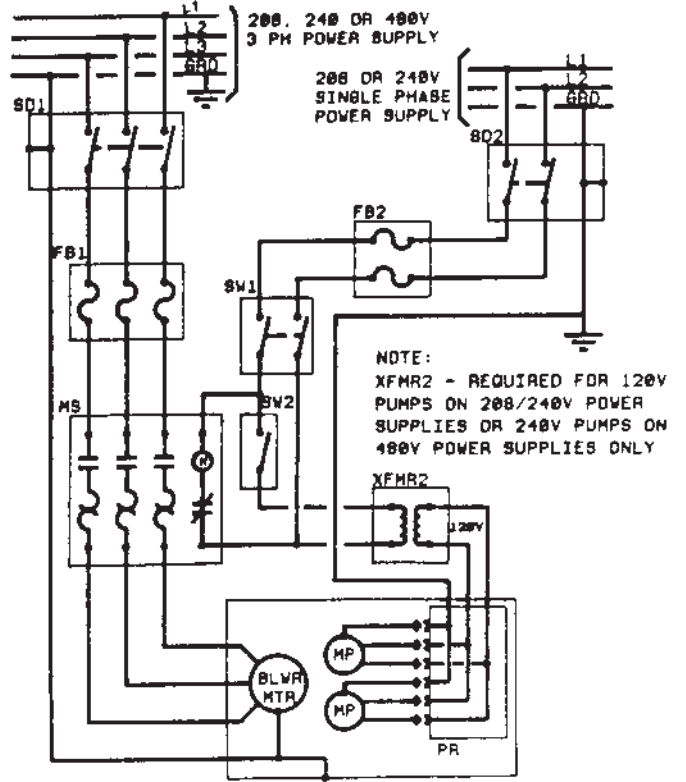

WIRING DIAGRAM F

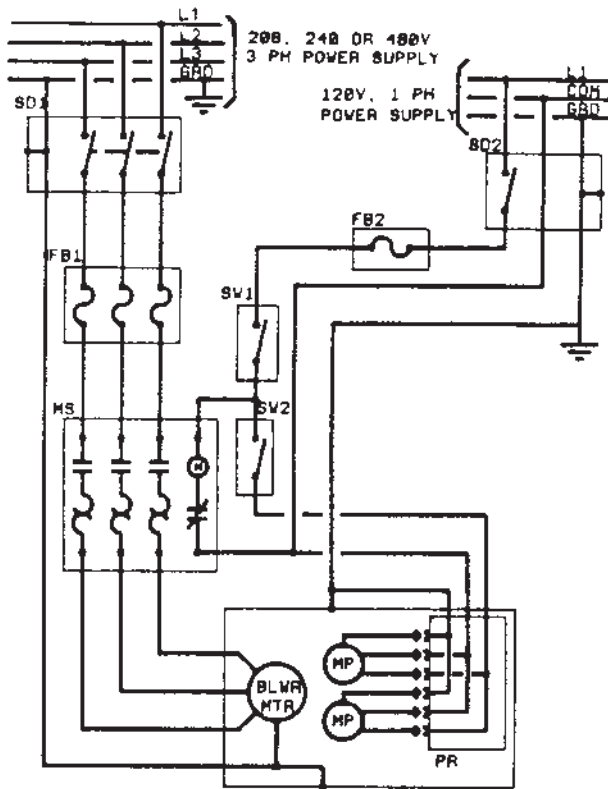

WIRING DIAGRAM E

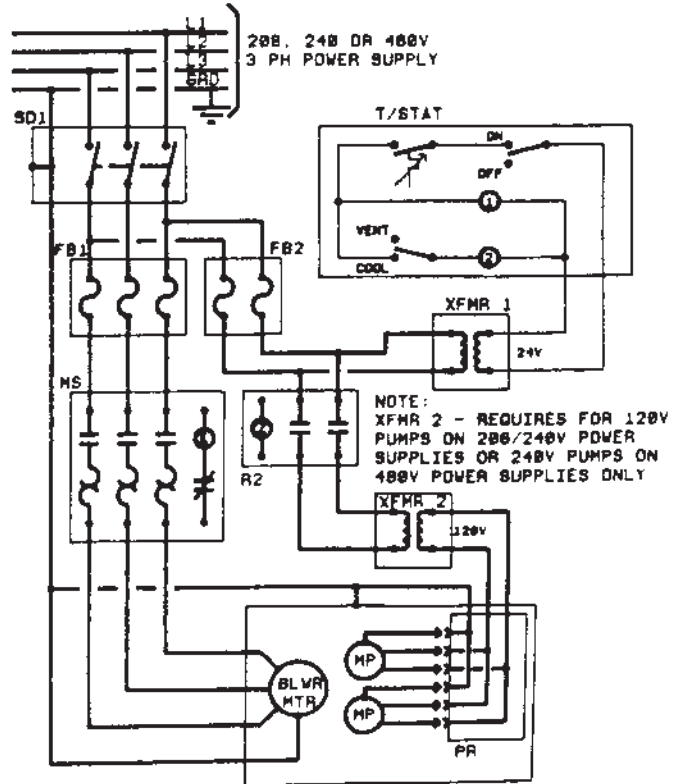

WIRING DIAGRAM G

MOTOR MOUNTING PILE HOLE PATTERN

MD628

MS628

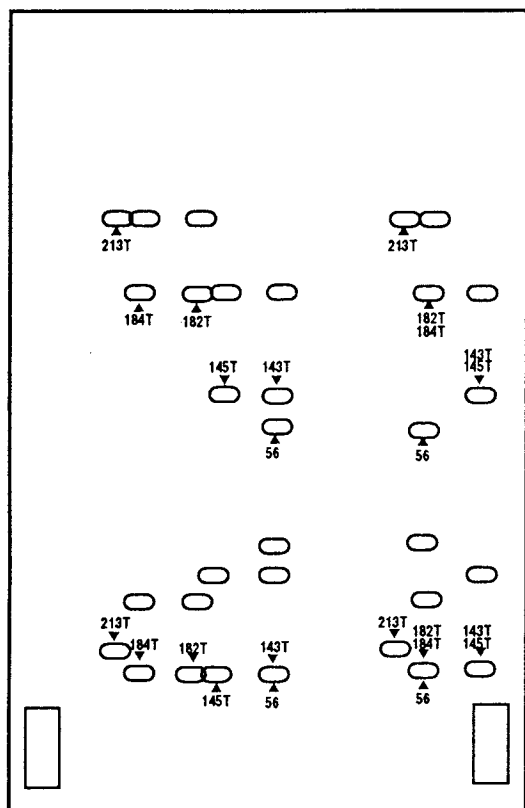

FIGURE 13

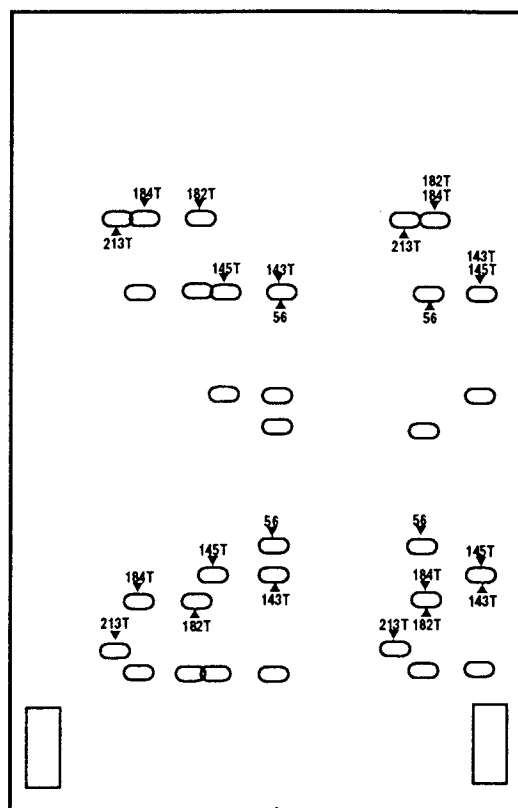

FIGURE 14

NOTES

1. Wire clip (approximate location).
2. G.F.C.I. protected receptacle in weatherproof box with cover. Use pre-drilled holes on blower housing to locate box as indicated.
3. To control panel (pump circuit).
4. Pump location and mounting procedure:
 - Disconnect electrical power to cooler prior to pump installation.
 - Position pump as shown (1 each media section) making sure pump base is setting flat on bottom pan. Secure using bolt and nut (supplied).
 - Route pump cord as shown.

MOTOR FRAME	GE SINGLE PHASE HP	EMERSON SINGLE PHASE HP	GE 3 PHASE HP	EMERSON 3 PHASE HP
56	1	1, 1-1/2, 2		
143T			1	1
145T	1-1/2, 2		1-1/2, 2	1-1/2, 2
182T			3	3
184T			5	5
213T			7-1/2	7-1/2

CAUTION Route pump cord through wire clip making sure cord does not touch water in the bottom pan.

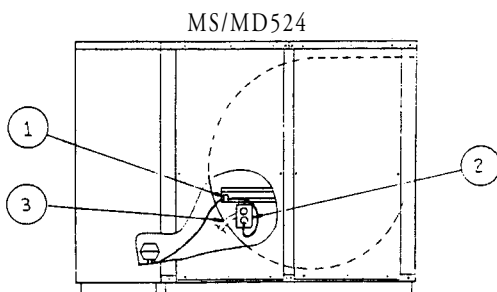

FIGURE 15

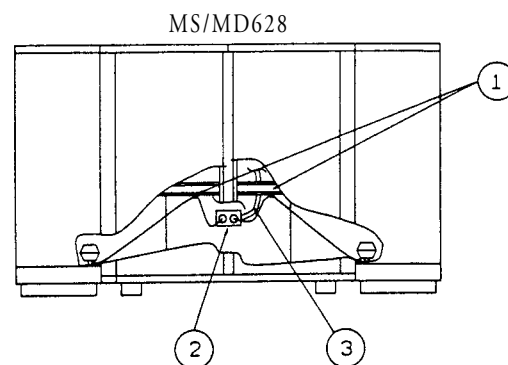

FIGURE 16

TROUBLESHOOTING

SYMPTOM	POSSIBLE CAUSES	REMEDY
Unit fails to start or deliver air	<ol style="list-style-type: none"> 1. No electrical power to unit <ol style="list-style-type: none"> a. Fuse blown b. Circuit breaker tripped 2. Cord(s) damaged or unplugged 3. Belt too loose or too tight 4. Motor overheated and frozen <ol style="list-style-type: none"> a. Belt too tight or broken b. Blower wheel bearings dry c. Motor overloaded d. Faulty wiring or shorts 	<ol style="list-style-type: none"> 1. Check power <ol style="list-style-type: none"> a. Replace fuse* b. Reset breaker* *If condition persists, call electrician 2. Plug in cord or replace 3. Adjust belt tension 4. Replace motor <ol style="list-style-type: none"> a. Adjust belt tension or replace b. Lubricate blower bearings c. Using ammeter, adjust motor to full load nameplate amps d. Call electrician
Unit starts but air delivery inadequate	<ol style="list-style-type: none"> 1. Lack of sufficient air exhaust 2. Motor underloaded 3. Belt too loose 4. Pad plugged 	<ol style="list-style-type: none"> 1. Open windows or doors to increase ventilation 2. Using ammeter, adjust motor to full amps per nameplate 3. Adjust belt tension or replace 4. Rinse or replace pad
Inadequate cooling	<ol style="list-style-type: none"> 1. Inadequate exhaust in house 2. Air registers improperly positioned 3. Insufficient water / pad not wet <ol style="list-style-type: none"> a. Pad plugged b. Distribution holes clogged c. Pump not working d. Loose connection in water system e. Pump basket clogged 	<ol style="list-style-type: none"> 1. Open windows or doors to increase ventilation 2. Adjust to direct air as desired 3. Check water distribution system <ol style="list-style-type: none"> a. Rinse or replace pad b. Clear holes c. Unplug pump. Clean impeller housing of foreign matter d. Check for leaks and correct e. Clean basket
Motor cycles on and off	<ol style="list-style-type: none"> 1. Excessive belt tension <ol style="list-style-type: none"> a. Blower shaft tight or frozen 2. Motor overloaded 3. Incorrect sheave adjustment 4. Pulleys misaligned 5. Service panels, pad or inlet panels are removed 	<ol style="list-style-type: none"> 1. Adjust belt tension <ol style="list-style-type: none"> a. Lubricate blower bearings and rotate shaft by hand (power off) 2. Using ammeter, adjust motor to full load nameplate amps 3. Serviceman should correct 4. Correct alignment 5. Never operate unit with service panels, pad or inlet panel removed. This will result in an overloaded condition and may damage the motor.
Water draining from overflow standpipe	<ol style="list-style-type: none"> 1. Float arm improperly adjusted 2. Seat in float valve leaking 3. Standpipe not tight 	<ol style="list-style-type: none"> 1. Adjust float 2. Replace float valve 3. Tighten standpipe
Knocking or banging sound	<ol style="list-style-type: none"> 1. Bearings dry <ol style="list-style-type: none"> a. Wheel rubbing blower housing or rotating off-balance 	<ol style="list-style-type: none"> 1. Lubricate blower bearings <ol style="list-style-type: none"> a. Inspect blower shaft, collars, belt and pulley alignment and motor mounting
Blower shakes or rattles	<ol style="list-style-type: none"> 1. Belt or pulley loose 	<ol style="list-style-type: none"> 1. Inspect belt and adjust if needed. Adjust or replace pulley.
Excessive humidity in house	<ol style="list-style-type: none"> 1. Inadequate exhaust 	<ol style="list-style-type: none"> 1. Open doors or windows to increase ventilation
Musty or unpleasant odor	<ol style="list-style-type: none"> 1. Stale or stagnant water in reservoir <ol style="list-style-type: none"> a. Pad mildewed or clogged b. Pad not completely wet before cooler is turned on c. New media (pad) 	<ol style="list-style-type: none"> 1. Drain, flush and clean reservoir <ol style="list-style-type: none"> a. Check drain pump b. Turn on water before starting unit c. <u>Note:</u> There will be a slight odor noticed on initial startup. The odor will disappear within the first few days of operation when drain pump is used.